

Maße

Messerschleuse - ZSM

JAUDT

NW: A x B

BH: E

Geräte Nr.: 6314...

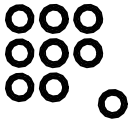

Dimensions

cutter feeder

Dimension

ecluse a roue cellulaire - couteau

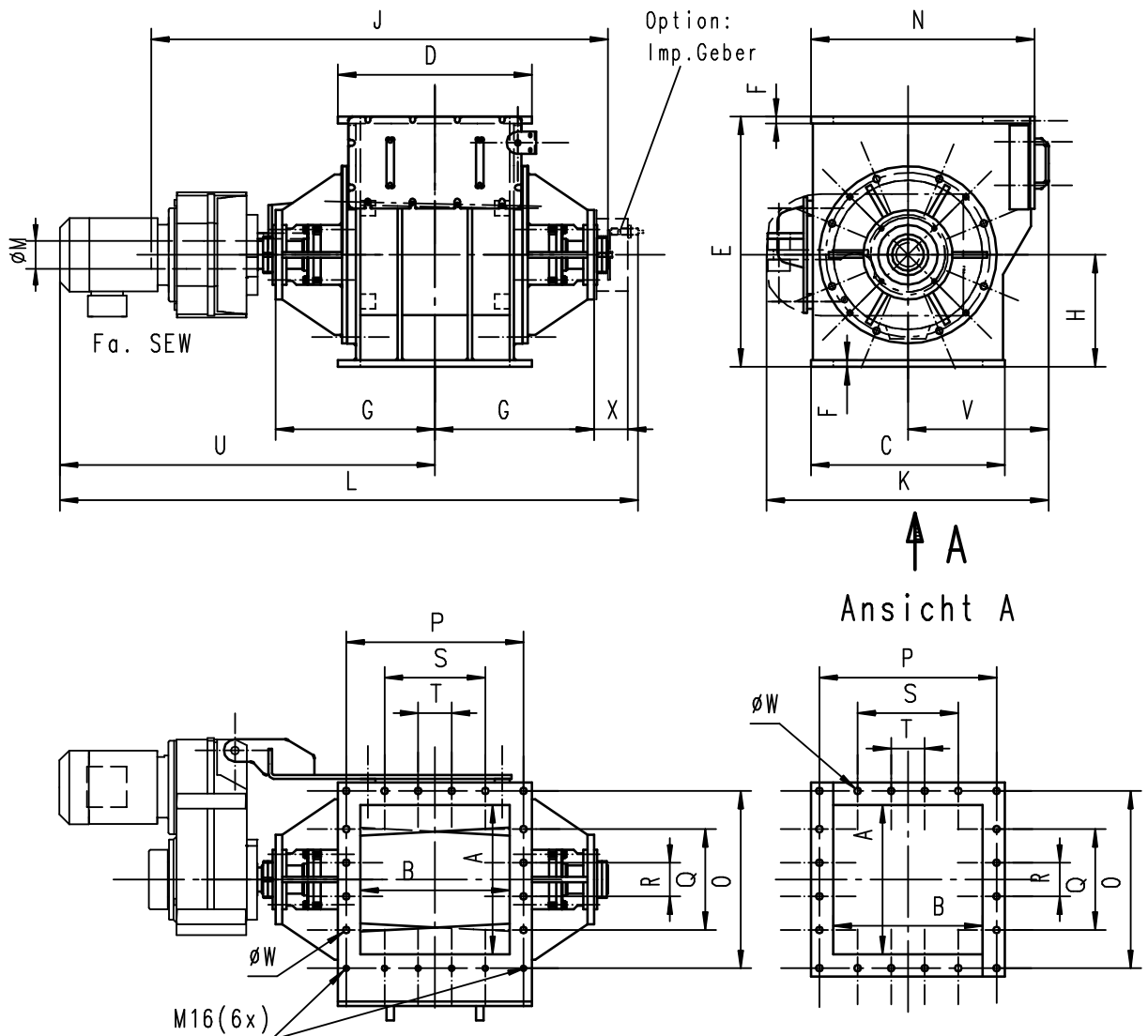

Ansicht A

Änderungen vorbehalten / subject to alterations / réserve de modification

NW AxB	C	D	E	F	G	H	J	K	L	ϕM	N	O
400x400	520	520	670	18	427	300	1224,5	756	1550	75	599	475
500x500	620	620	770	22	477	350	1324,5	834	1670	75	677	570
630x630	750	750	900	22	556	450	1557	941	1900	80	787	710
700x700	820	820	1000	22	591	500	(*)	(*)	(*)	(*)	820	770
700x1000	820	1120	1000	22	741	500	(*)	(*)	(*)	(*)	820	770

NW AxB	P	Q	R	S	T	U	V	ϕW	X	Gewicht
400x400	475	270	90	270	90	1006	377	18	90	570
500x500	570	342	114	342	114	1072	405	18	90	720
630x630	710	426	142	426	142	1222	450	18	90	1100
700x700	770	6x100=600	200	6x100=600	200	(*)	450	18	110	-
700x1000	1070	6x100=600	200	9x100=900	100	(*)	456	18	110	-

(*) auf Anfrage